

# Multi Digital Power Transducer



## MPW-400



Ordering: MPW-400-3-2-HI-1-N



Element  
3 : 3 P 3W  
4 : 4 P 4W

Current Input  
1 : 0-1A  
2 : 0-5A

Power  
HI : AC 85-265V , DC 80-330V  
LO : DC 20-40V

Option

N : None

A : Fault current detection

B : Overcurrent direction signal

Communication Port

1 : RS-232 + Ethernet

2 : RS-485

Y : Special ordering

## Specifications

Ac voltage input rang	: 10-300 V True RMS for input impedance 1 MΩ ±3%
Ac current input rang	: 0.005-1A, maximum 1.2A, 0.025-5A maximum 6A
Frequency	: 46 – 64 Hz
Burden	: Voltage < 0.15VA at 300V ,Current < 0.2VA of rating : Overload withstand 20 CT @ 500 ms
Fault current Detection	: 20 times of current rating Overcurrent directional signal
Accuracy	: Normal Voltage and Current 0.2% @full scale : Fault Current 5% @full scale
Power Supply	: AC 85-265V ,DC 80-330V ,DC20-40V
Digital Output	: 2 Output Isolated @ 24VDC for over current alarm
Interfaces	: 1 x RS232 port and 1 x Ethernet Lan or 1xRS485 : Baud Rate 4800 - 38400 bps (Configurable)
Protocols	: MODBUS RTU (RS232) , MODBUS TCP (RJ45) : Device address 1 - 254 (Configurable) : Re-configurable Register Address able to User Mapping
Real Time Clock (RTC)	: Maximum deviation 2 second per hour
Operating condition	: 0-60 °C ( 20 to 90% RH non-condensed )
Storage condition	: 0-70 °C ( 20 to 90% RH non-condensed )
Mounting	: DIN Rail, ABS Plastic case
Software	: Web browser Configuration @ Windows OS base
Response time	: Data Updating Interval 200mSec
Measured Power system	: 3Ph4W , 3Ph4W , PT Ratio : 1.0 – 5000.0 ,CT Ratio : 1.0 – 5000.0
Measured Parameter/Accuracy	: Volt 0.2% FS , Amp 0.2% FS , PF 0.5% FS : Frequency 0.25% FS , Watt 0.5% FS , Var 0.5% FS : VA 0.5% FS , WH 1.0 rd , VarH 1.0 rd
Dimensions	: 100 x 70 x 110 MM

# OUTLINE DIMENSION

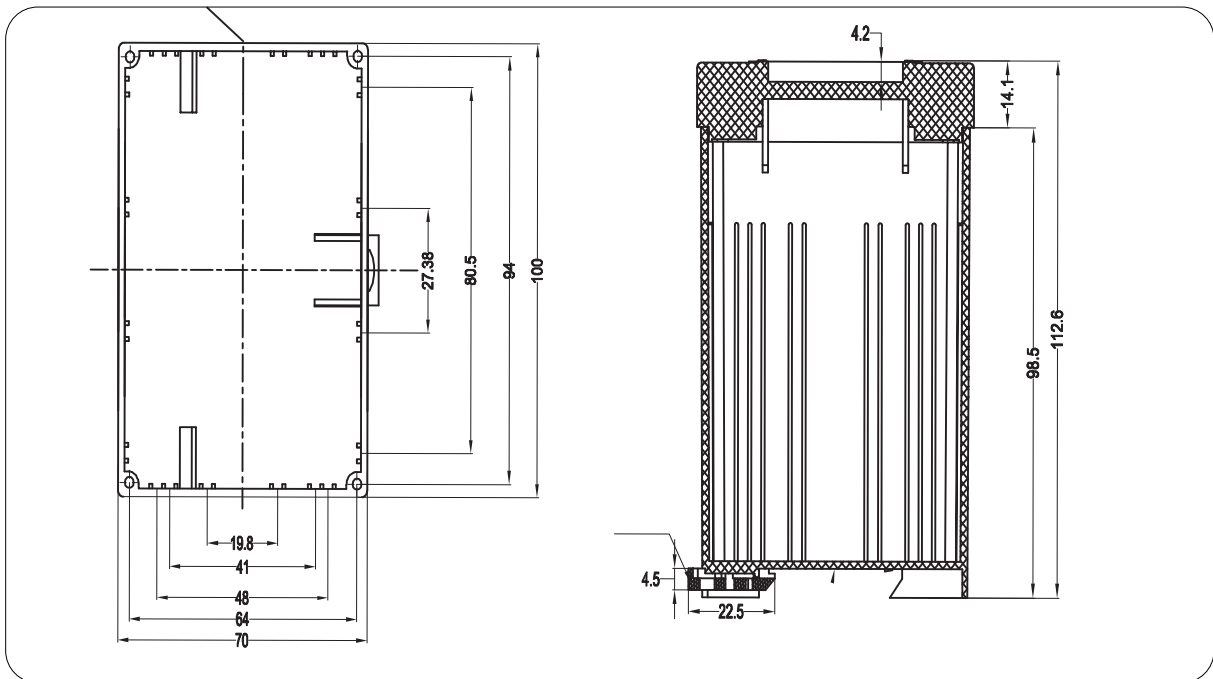
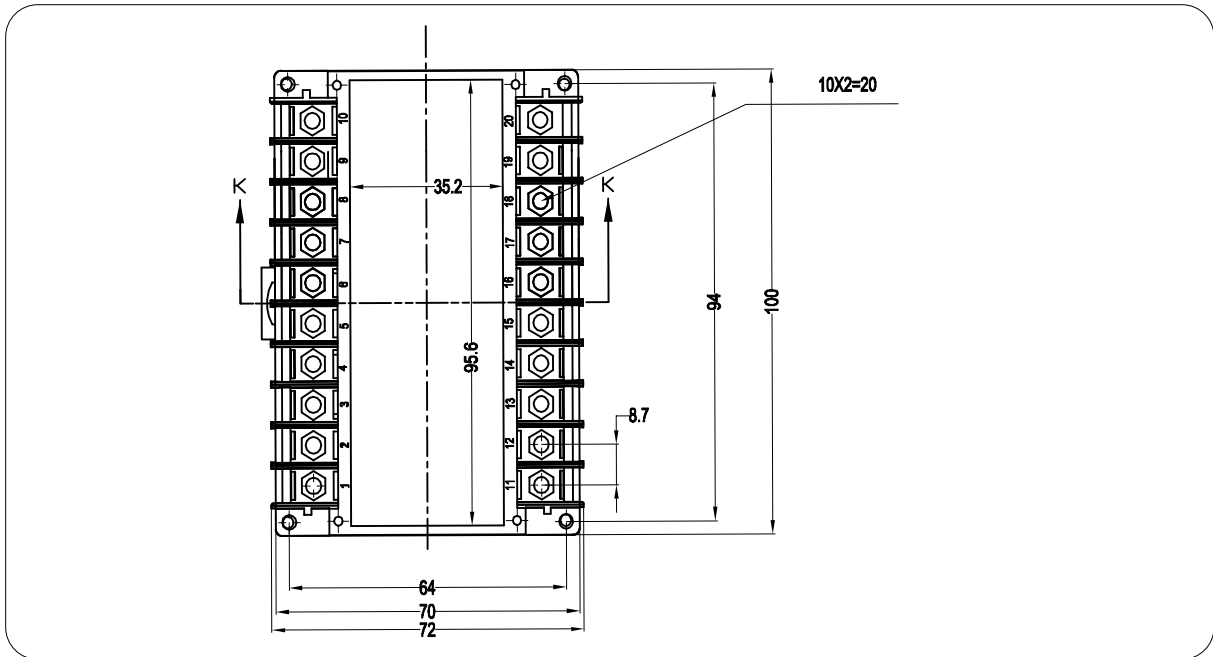

## Winling Technology Ltd.

9F.-8, No.16, Ln. 609, Sec. 5, Chongxin Rd., Sanchong Dist., New Taipei City 24159, Taiwan  
 TEL: 886-2-29996610 FAX: 886-2-29996620  
 E-mail: dent.csn@msa.hinet.net or allen1025@winling.com.tw  
 www.winling.com.tw